



**Technical and Test Institute
for Construction Prague**

Prosecká 811/76a
190 00 Prague
Czech Republic
eota@tzus.cz



Member of



www.eota.eu

European Technical Assessment

**ETA 22/0323
of 18/07/2022**

Technical Assessment Body issuing the ETA: Technical and Test Institute
for Construction Prague

Trade name of the construction product

PROFIX PIT+
PROFIX PIT COLD+
PROFIX PIT HOT+

**Product family to which the construction
product belongs**

Product area code: 33
Bonded injection type anchor for use in
cracked and uncracked concrete

Manufacturer

PROFIX AG
Kanalstrasse 23
CH-4415 Lausen
Switzerland

Manufacturing plant

Plant 1

**This European Technical Assessment
contains**

21 pages including 18 Annexes which form
an integral part of this assessment.

**This European Technical Assessment is
issued in accordance with regulation
(EU) No 305/2011, on the basis of**

EAD 330499-01-0601
Bonded fasteners for use in concrete

Translations of this European Technical Assessment in other languages shall fully correspond to the original issued document and should be identified as such.

Communication of this European Technical Assessment, including transmission by electronic means, shall be in full (excepted the confidential Annex(es) referred to above). However, partial reproduction may be made, with the written consent of the issuing Technical Assessment Body - Technical and Test Institute for Construction Prague. Any partial reproduction has to be identified as such.

1. Technical description of the product

The PROFIX PIT+, PROFIX PIT COLD+ (faster curing time) and PROFIX PIT HOT+ (extended processing time) with steel elements is bonded anchor (injection type).

Steel elements can be galvanized or stainless steel threaded rod or rebar.

Steel element is placed into a drilled hole filled with injection mortar. The steel element is anchored via the bond between metal part, injection mortar and concrete. The anchor is intended to be used with embedment depth from 8 diameters to 20 diameters.

The illustration and the description of the product are given in Annex A.

2. Specification of the intended use in accordance with the applicable EAD

The performances given in Section 3 are only valid if the anchor is used in compliance with the specifications and conditions given in Annex B.

The provisions made in this European Technical Assessment are based on an assumed working life of the anchor of 50 years and 100 years. The indications given on the working life cannot be interpreted as a guarantee given by the producer, but are to be regarded only as a means for choosing the products in relation to the expected economically reasonable working life of the works.

3. Performance of the product and references to the methods used for its assessment

3.1 Mechanical resistance and stability (BWR 1)

Essential characteristic	Performance
Characteristic resistance to tension load (static and quasi-static loading)	See Annex C 1 to C 4
Characteristic resistance to shear load (static and quasi-static loading)	See Annex C 5, C 6
Displacements under short-term and long-term loading	See Annex C 7
Characteristic resistance for seismic performance categories C1 and C2	See Annex C 8 to C 10

3.2 Hygiene, health and environment (BWR 3)

No performance determined.

3.3 General aspects relating to fitness for use

Durability and serviceability are only ensured if the specifications of intended use according to Annex B 1 are kept.

4. Assessment and verification of constancy of performance (AVCP) system applied with reference to its legal base

According to the Decision 96/582/EC of the European Commission¹ the system of assessment verification of constancy of performance (see Annex V to Regulation (EU) No 305/2011) given in the following table apply.

Product	Intended use	Level or class	System
Metal anchors for use in concrete	For fixing and/or supporting to concrete, structural elements (which contributes to the stability of the works) or heavy units	-	1

¹ Official Journal of the European Communities L 254 of 08.10.1996

5. Technical details necessary for the implementation of the AVCP system, as provided in the applicable EAD

The factory production control shall be in accordance with the control plan which is a part of the technical documentation of this European Technical Assessment. The control plan is laid down in the context of the factory production control system operated by the manufacturer and deposited at Technical and Test Institute for Construction Prague.² The results of factory production control shall be recorded and evaluated in accordance with the provisions of the control plan.

Issued in Prague on 18.07.2022

By
Ing. Jiří Studnička, Ph.D.
Head of the Technical Assessment Body



² The control plan is a confidential part of the documentation of the European Technical Assessment, but not published together with the ETA and only handed over to the approved body involved in the procedure of AVCP.

Threaded rod

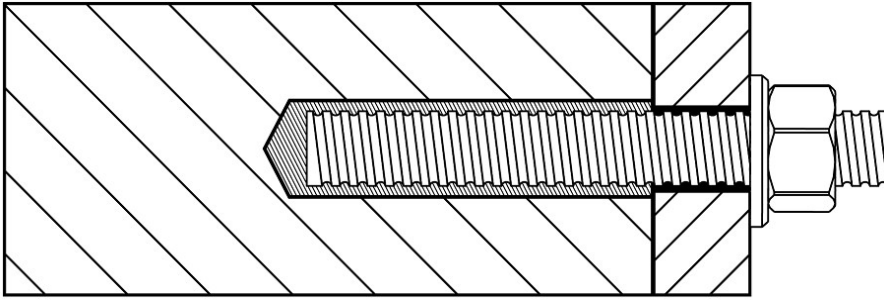

Reinforcing bar

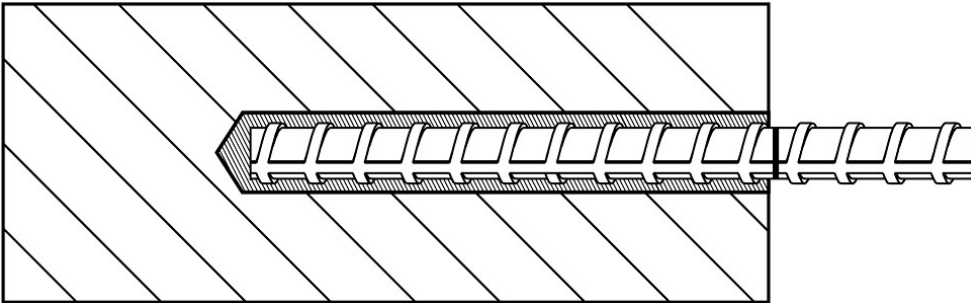

PROFIX PIT+, PROFIX PIT COLD+, PROFIX PIT HOT+

Product description
Installed conditions

Annex A 1

Coaxial cartridge

PROFIX PIT 150+, PROFIX PIT COLD 150+, PROFIX PIT HOT 150+	150 ml
PROFIX PIT 380+, PROFIX PIT COLD 380+, PROFIX PIT HOT 380+	380 ml
PROFIX PIT 400+, PROFIX PIT COLD 400+, PROFIX PIT HOT 400+	400 ml
PROFIX PIT 410+, PROFIX PIT COLD 410+, PROFIX PIT HOT 410+	410 ml

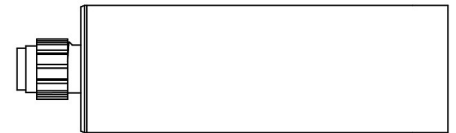

Side by side cartridge

PROFIX PIT 345+, PROFIX PIT COLD 345+, PROFIX PIT HOT 345+	345 ml
PROFIX PIT 825+, PROFIX PIT COLD 825+, PROFIX PIT HOT 825+	825 ml

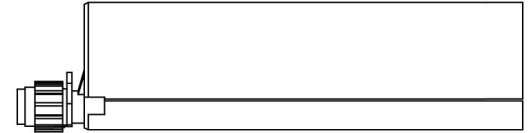

Two part foil in a single piston component cartridge

PROFIX PIT 150+, PROFIX PIT COLD 150+, PROFIX PIT HOT 150+	150 ml
PROFIX PIT 170+, PROFIX PIT COLD 170+, PROFIX PIT HOT 170+	170 ml
PROFIX PIT 300+, PROFIX PIT COLD 300+, PROFIX PIT HOT 300+	300 ml
PROFIX PIT 550+, PROFIX PIT COLD 550+, PROFIX PIT HOT 550+	550 ml
PROFIX PIT 850+, PROFIX PIT COLD 850+, PROFIX PIT HOT 850+	850 ml

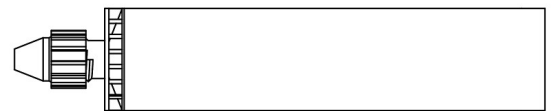

Marking of the mortar cartridges

Identifying mark of the producer, Trade name, Charge code number, Storage life, Curing and processing time

Mixing nozzle

PIT-SM

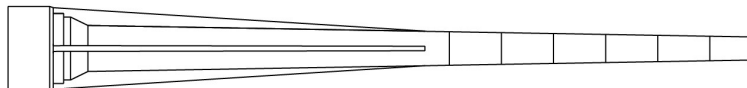

PIT-SMK

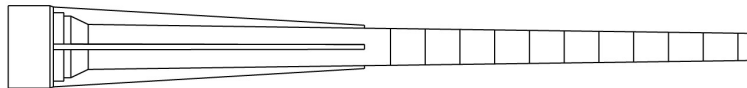

PIT-SMEF



PIT-SM360

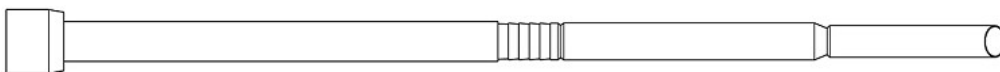

PIT-SM850

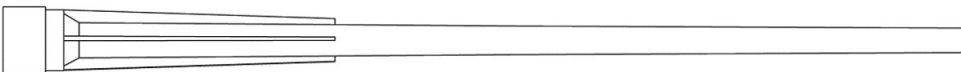

PROFIX PIT+, PROFIX PIT COLD+, PROFIX PIT HOT+

Product description
Injection system

Annex A 2

Threaded rod M8, M10, M12, M16, M20, M24, M27, M30

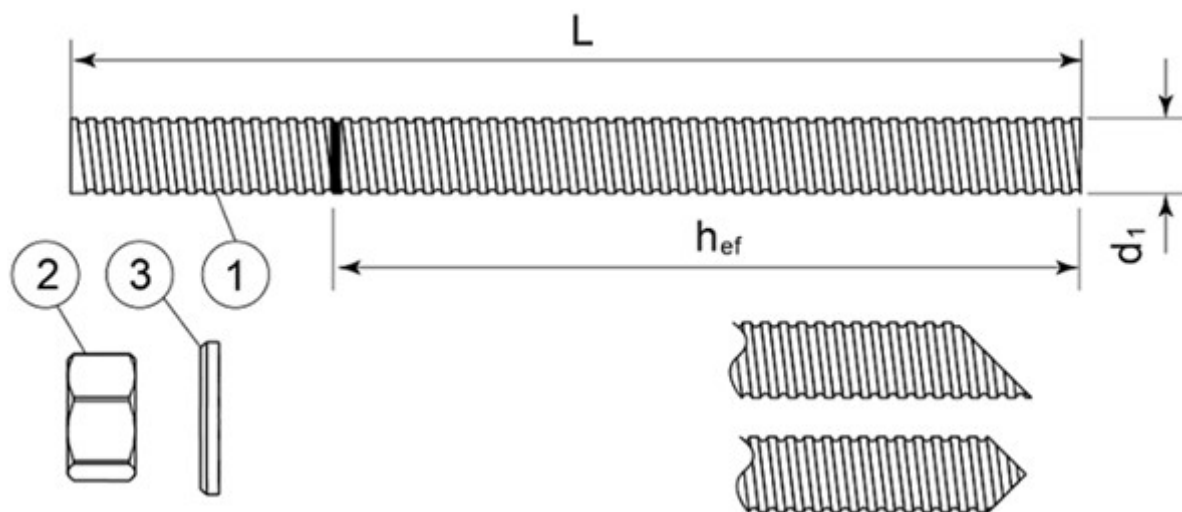

Standard commercial threaded rod with marked embedment depth

Part	Designation	Material
Steel, zinc plated $\geq 5 \mu\text{m}$ acc. to EN ISO 4042 or Steel, Hot-dip galvanized $\geq 40 \mu\text{m}$ acc. to EN ISO 1461 and EN ISO 10684 or Steel, zinc diffusion coating $\geq 15 \mu\text{m}$ acc. to EN 13811		
1	Anchor rod	Steel, EN 10087 or EN 10263 Property class 4.6, 5.8, 8.8, 10.9* EN ISO 898-1
2	Hexagon nut EN ISO 4032	According to threaded rod, EN 20898-2
3	Washer EN ISO 887, EN ISO 7089, EN ISO 7093 or EN ISO 7094	According to threaded rod
Stainless steel		
1	Anchor rod	Material: A2-70, A4-70, A4-80, EN ISO 3506
2	Hexagon nut EN ISO 4032	According to threaded rod
3	Washer EN ISO 887, EN ISO 7089, EN ISO 7093 or EN ISO 7094	According to threaded rod
High corrosion resistant steel		
1	Anchor rod	Material: 1.4529, 1.4565, EN 10088-1
2	Hexagon nut EN ISO 4032	According to threaded rod
3	Washer EN ISO 887, EN ISO 7089, EN ISO 7093 or EN ISO 7094	According to threaded rod

*Galvanized rod of high strength are sensitive to hydrogen induced brittle failure

PROFIX PIT+, PROFIX PIT COLD+, PROFIX PIT HOT+

Product description
Threaded rod and materials

Annex A 3

Rebar Ø8, Ø10, Ø12, Ø16, Ø20, Ø25, Ø32



Standard commercial reinforcing bar with marked embedment depth

Product form		Bars and de-coiled rods	
Class		B	C
Characteristic yield strength f_{yk} or $f_{0,2k}$ (MPa)		400 to 600	
Minimum value of $k = (f_t/f_y)_k$		$\geq 1,08$	$\geq 1,15$ < 1,35
Characteristic strain at maximum force ϵ_{uk} (%)		$\geq 5,0$	$\geq 7,5$
Bendability		Bend/Rebend test	
Maximum deviation from nominal mass (individual bar) (%)	Nominal bar size (mm) ≤ 8	$\pm 6,0$	
	> 8	$\pm 4,5$	
Bond: Minimum relative rib area, $f_{R,min}$	Nominal bar size (mm) 8 to 12	0,040	
	> 12	0,056	

PROFIX PIT+, PROFIX PIT COLD+, PROFIX PIT HOT+

Product description
Rebars and materials

Annex A 4

Specifications of intended use

Anchorage subject to:

- Static and quasi-static load.
- Seismic actions category C1 (max w = 0,5 mm): threaded rod size M10, M12, M16, M20, M24
- Seismic actions category C2 (max w = 0,8 mm): threaded rod size M12, M16, M20

Base materials

- Uncracked concrete.
- Cracked and uncracked concrete for threaded rod size M10, M12, M16, M20, M24
- Reinforced or unreinforced normal weight concrete of strength class C20/25 at minimum and C50/60 at maximum according EN 206:2013.

Temperature range:

- -40°C to +80°C (max. short. term temperature +80°C and max. long term temperature +50°C)

Use conditions (Environmental conditions)

- (X1) Structures subject to dry internal conditions (zinc coated steel, stainless steel, high corrosion resistance steel).
- (X2) Structures subject to external atmospheric exposure (including industrial and marine environment) and to permanently damp internal condition, if no particular aggressive conditions exist (stainless steel A4, high corrosion resistant steel).
- (X3) Structures subject to external atmospheric exposure and to permanently damp internal condition, if other particular aggressive conditions exist (high corrosion resistant steel).

Note: Particular aggressive conditions are e.g. permanent, alternating immersion in seawater or the splash zone of seawater, chloride atmosphere of indoor swimming pools or atmosphere with extreme chemical pollution (e.g. in desulphurization plants or road tunnels where de-icing materials are used).

Concrete conditions:

- I1 – installation in dry or wet (water saturated) concrete and use in service in dry or wet concrete.
- I2 – installation in water-filled (not sea water) and use in service in dry or wet concrete

Design:

- The anchorages are designed in accordance with the EN 1992-4 under the responsibility of an engineer experienced in anchorages and concrete work.
- Verifiable calculation notes and drawings are prepared taking account of the loads to be anchored. The position of the anchor is indicated on the design drawings.
- Anchorages under seismic actions (cracked concrete) have to be designed in accordance with EN 1992-4.

Installation:

- Hole drilling by hammer drill mode.
- Anchor installation carried out by appropriately qualified personnel and under the supervision of the person responsible for technical matters of the site.

Installation direction:

- D3 – downward and horizontal and upwards (e.g. overhead) installation

PROFIX PIT+, PROFIX PIT COLD+, PROFIX PIT HOT+

Intended use
Specifications

Annex B 1

Applicator gun

A



B



C



D



E



F



G



Applicator gun	A	B	C	D	E	F	G
Cartridge	Coaxial 380ml 400ml 410ml	Side by side 345ml	Foil capsule 150ml 300ml 550ml	Foil capsule 150ml 300ml	Coaxial 150ml	Side by side 825ml	Foil capsule 850ml

Cleaning brush

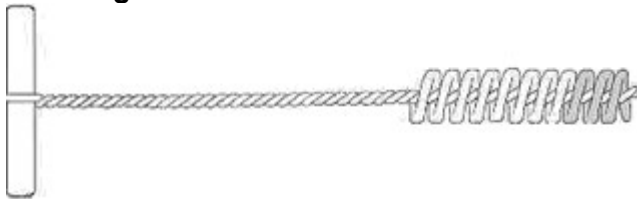

PROFIX PIT+, PROFIX PIT COLD+, PROFIX PIT HOT+

Intended use
Applicator guns
Cleaning brush

Annex B 2

Installation instructions

1. Drill the hole to the correct diameter and depth using a rotary percussion drilling machine.
2. Thoroughly clean the hole in the following sequence using the brush with the required extensions and a blow pump:

Blow Clean x2.

Brush Clean x2.

Blow Clean x2.

Brush Clean x2.

Blow Clean x2.

Remove standing water from the hole prior to cleaning to achieve maximum performance.

3. Select the appropriate static mixer nozzle for the installation, open the cartridge/cut foil pack and screw nozzle onto the mouth of the cartridge. Insert the cartridge into a good quality applicator (gun).
4. Extrude the first part of the cartridge to waste until an even colour has been achieved without streaking in the resin.
5. If necessary, cut the extension tube to the depth of the hole and push onto the end of the mixer nozzle, and fit the correct resin stopper to the other end.
6. Insert the mixer nozzle (or the extension tube with resin stopper when necessary) to the bottom of the hole. Begin to extrude the resin and slowly withdraw the mixer nozzle from the hole ensuring that there are no air voids as the mixer nozzle is withdrawn. Fill the hole to approximately $\frac{1}{2}$ to $\frac{3}{4}$ full and withdraw the nozzle completely.
7. Insert the clean threaded bar, free from oil or other release agents, to the bottom of the hole using a back and forth twisting motion ensuring all the threads are thoroughly coated. Adjust to the correct position within the stated working time.
8. Excess resin will be expelled from the hole evenly around the steel element showing that the hole is full.
This excess resin should be removed from around the mouth of the hole before it sets.
9. Leave the anchor to cure.
Do not disturb the anchor until the appropriate loading time has elapsed depending on the substrate conditions and ambient temperature.
10. Attach the fixture and tighten the nut to the recommended torque.
Do not overtighten.

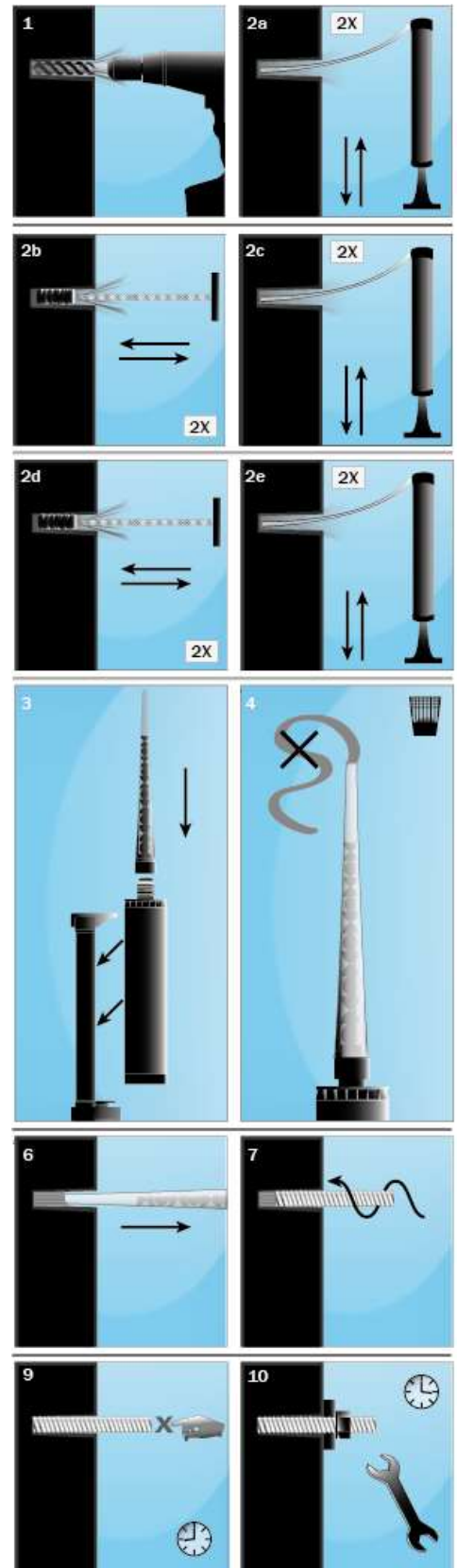

PROFIX PIT+, PROFIX PIT COLD+, PROFIX PIT HOT+

Intended use
Installation procedure

Annex B 3

Table B1: Installation parameters of threaded rod

Size		M8	M10	M12	M16	M20	M24	M27	M30	
Nominal drill hole diameter	$\varnothing d_0$ [mm]	10	12	14	18	22	26	30	35	
Diameter of cleaning brush	d_b [mm]	14	14	20	20	29	29	40	40	
Torque moment	$\max T_{fix}$ [Nm]	10	20	40	80	150	200	240	275	
Depth of drill hole for $h_{ef,min}$	$h_0 = h_{ef}$ [mm]	64	80	96	128	160	192	216	240	
Depth of drill hole for $h_{ef,max}$	$h_0 = h_{ef}$ [mm]	160	200	240	320	400	480	540	600	
Minimum edge distance	c_{min} [mm]	35	40	50	65	80	96	110	120	
Minimum spacing	s_{min} [mm]	35	40	50	65	80	96	110	120	
Minimum thickness of member	h_{min} [mm]	$h_{ef} + 30 \text{ mm} \geq 100 \text{ mm}$					$h_{ef} + 2d_0$			

Table B2: Installation parameters of rebar

Size		Ø8	Ø10	Ø12	Ø16	Ø20	Ø25	Ø32	
Nominal drill hole diameter	$\varnothing d_0$ [mm]	12	14	16	20	25	32	40	
Diameter of cleaning brush	d_b [mm]	14	14	19	22	29	40	42	
Depth of drill hole for $h_{ef,min}$	$h_0 = h_{ef}$ [mm]	64	80	96	128	160	200	256	
Depth of drill hole for $h_{ef,max}$	$h_0 = h_{ef}$ [mm]	160	200	240	320	400	500	640	
Minimum edge distance	c_{min} [mm]	35	40	50	65	80	100	130	
Minimum spacing	s_{min} [mm]	35	40	50	65	80	100	130	
Minimum thickness of member	h_{min} [mm]	$h_{ef} + 30 \text{ mm} \geq 100 \text{ mm}$				$h_{ef} + 2d_0$			

Table B3: Minimum curing time

PROFIX PIT+			
Resin cartridge temperature [°C]	T Work [mins]	Base material Temperature [°C]	T Load [mins]
+10	30 mins	-10 to -5	24 hours
+5	20 mins	-5 to 0	300 mins
0 to +5	15 mins	0 to +5	210 mins
+5 to +10	10 mins	+5 to +10	145 mins
+10 to +15	8 mins	+10 to +15	85 mins
+15 to +20	6 mins	+15 to +20	75 mins
+20 to +25	5 mins	+20 to +25	50 mins
+25 to +30	4 mins	+25 to +30	40 mins

PROFIX PIT COLD+			
Resin cartridge temperature [°C]	T Work [mins]	Base material Temperature [°C]	T Load [mins]
+20	40 mins	-20 to -15 ¹⁾	24 hours
+20	30 mins	-15 to -10 ¹⁾	18 hours
+5	20 mins	-10 to -5	12 hours
+5	15 mins	-5 to 0	100 mins
0 to +5	10 mins	0 to +5	75 mins
+5 to +20	5 mins	+5 to +20	50 mins
+20	100 second	+20	20 mins

¹⁾ characteristic values of resistance see Annex C 2 and C 4, seismic performance see Annex C 10

PROFIX PIT HOT+			
Resin cartridge temperature [°C]	T Work [mins]	Base material Temperature [°C]	T Load [mins]
+15 to +20	15 mins	+15 to +20	5 hours
+15 to +25	10 mins	+20 to +25	145 mins
+15 to +30	7.5 mins	+25 to +30	85 mins
+15 to +35	5 mins	+30 to +35	50 mins
+15 to +40	3.5 mins	+35 to +40	40 mins

T work is typical gel time at highest temperature

T load is set at the lowest temperature

PROFIX PIT+, PROFIX PIT COLD+, PROFIX PIT HOT+

Intended use
Installation parameters
Curing time

Annex B 4

Table C1: Design method EN 1992-4
Characteristic values of resistance to tension load of threaded rod

Steel failure – Characteristic resistance										
Size			M8	M10	M12	M16	M20	M24	M27	M30
Steel grade 4.6	$N_{Rk,s}$	[kN]	15	23	34	63	98	141	184	224
Partial safety factor	γ_{Ms}	[-]	2,00							
Steel grade 5.8	$N_{Rk,s}$	[kN]	18	29	42	79	123	177	230	281
Partial safety factor	γ_{Ms}	[-]	1,50							
Steel grade 8.8	$N_{Rk,s}$	[kN]	29	46	67	126	196	282	367	449
Partial safety factor	γ_{Ms}	[-]	1,50							
Steel grade 10.9	$N_{Rk,s}$	[kN]	37	58	84	157	245	353	459	561
Partial safety factor	γ_{Ms}	[-]	1,33							
Stainless steel grade A2-70, A4-70	$N_{Rk,s}$	[kN]	26	41	59	110	172	247	321	393
Partial safety factor	γ_{Ms}	[-]	1,87							
Stainless steel grade A4-80	$N_{Rk,s}$	[kN]	29	46	67	126	196	282	367	449
Partial safety factor	γ_{Ms}	[-]	1,60							
Stainless steel grade 1.4529	$N_{Rk,s}$	[kN]	26	41	59	110	172	247	321	393
Partial safety factor	γ_{Ms}	[-]	1,50							
Stainless steel grade 1.4565	$N_{Rk,s}$	[kN]	26	41	59	110	172	247	321	393
Partial safety factor	γ_{Ms}	[-]	1,87							

Combined pullout and concrete cone failure in concrete C20/25											
Size			M8	M10	M12	M16	M20	M24	M27	M30	
Characteristic bond resistance in uncracked concrete for a working life of 50 years and 100 years											
Dry and wet concrete	$\tau_{Rk,ucr}$	[N/mm ²]	11	10	9,5	9	8,5	8	6,5	5,5	
Installation safety factor	γ_{inst}	[-]	1,2							1,4	
Flooded hole	$\tau_{Rk,ucr}$	[N/mm ²]	9	8	7,5	7	7	6			
Installation safety factor	γ_{inst}	[-]	1,4								
Factor for uncracked concrete 50/60	ψ_c	[-]	1								
Size			M10	M12	M16	M20	M24				
Characteristic bond resistance in cracked concrete for a working life of 50 years											
Dry and wet concrete	$\tau_{Rk,cr}$	[N/mm ²]	5,5	5,5	5,5	5	5				
Installation safety factor	γ_{inst}	[-]	1,2								
Flooded hole	$\tau_{Rk,cr}$	[N/mm ²]	5,5	5,5	5,5	5	5				
Installation safety factor	γ_{inst}	[-]	1,4								
Characteristic bond resistance in cracked concrete for a working life of 100 years											
Dry and wet concrete	$\tau_{Rk,cr}$	[N/mm ²]	4	4	4	3,5	3,5				
Installation safety factor	γ_{inst}	[-]	1,2								
Flooded hole	$\tau_{Rk,cr}$	[N/mm ²]	4	4	4	3,5	3,5				
Installation safety factor	γ_{inst}	[-]	1,4								
Factor for influence of sustained load for a working life 50 years	ψ_{sus}^0	[-]	0,73								
Factor for cracked concrete	C30/37 C40/50 C50/60	ψ_c	1,12 1,23 1,30								

Concrete cone failure			
Factor for concrete cone failure for uncracked concrete	$k_{ucr,N}$	[-]	11
Factor for concrete cone failure for cracked concrete	$k_{cr,N}$	[-]	7,7
Edge distance	$c_{cr,N}$	[mm]	1,5 h_{ef}

Splitting failure											
Size			M8	M10	M12	M16	M20	M24	M27	M30	
Edge distance	$c_{cr,sp}$	[mm]	1,5 h_{ef}								
Spacing	$s_{cr,sp}$	[mm]	3,0 h_{ef}								

PROFIX PIT+, PROFIX PIT COLD+, PROFIX PIT HOT+

Performances

Design according to EN 1992-4
Characteristic resistance for tension loads - threaded rod

Annex C 1

Table C2: Design method EN 1992-4
 Characteristic values of resistance to tension load of threaded rod for
 PROFIX PIT COLD+ with installation temperature < -10°C

Steel failure – Characteristic resistance										
See Annex C 1										

Combined pullout and concrete cone failure in concrete C20/25											
Size			M8	M10	M12	M16	M20	M24	M27	M30	
Characteristic bond resistance in uncracked concrete for a working life of 50 years and 100 years											
Dry and wet concrete	$\tau_{Rk,ucr}$	[N/mm ²]	11,0	10,0	9,5	9,0	8,5	7,5	6,5	5,5	
Installation safety factor	γ_{inst}	[-]	1,2						1,4		
Flooded hole	$\tau_{Rk,ucr}$	[N/mm ²]	8,5	8,0	7,5	7,0	6,5	6,0	/		
Installation safety factor	γ_{inst}	[-]	1,4								
Factor for uncracked concrete 50/60	ψ_c	[-]	1								
Size			M10	M12	M16	M20	M24				
Characteristic bond resistance in cracked concrete for a working life of 50 years											
Dry and wet concrete	$\tau_{Rk,cr}$	[N/mm ²]	5,5	5,5	5,5	5,0	5,0				
Installation safety factor	γ_{inst}	[-]	1,2								
Flooded hole	$\tau_{Rk,cr}$	[N/mm ²]	5,5	5,5	5,5	5,0	5,0				
Installation safety factor	γ_{inst}	[-]	1,4								
Characteristic bond resistance in cracked concrete for a working life of 100 years											
Dry and wet concrete	$\tau_{Rk,cr}$	[N/mm ²]	3,5	3,5	3,5	3,5	3,5	3,5	3,5		
Installation safety factor	γ_{inst}	[-]	1,2								
Flooded hole	$\tau_{Rk,cr}$	[N/mm ²]	3,5	3,5	3,5	3,5	3,5	3,5	3,5		
Installation safety factor	γ_{inst}	[-]	1,4								
Factor for influence of sustained load for a working life 50 years	ψ^0_{sus}	[-]	0,73								
Factor for cracked concrete	C30/37	ψ_c	[-]	1,12							
	C40/50			1,23							
	C50/60			1,30							

Concrete cone failure										
See Annex C 1										

Splitting failure										
See Annex C 1										

PROFIX PIT COLD+	Annex C 2
Performances Design according to EN 1992-4 Characteristic resistance for tension loads - threaded rod	

Table C3: Design method EN 1992-4
Characteristic values of resistance to tension load of rebar

Steel failure – Characteristic resistance									
Size			Ø8	Ø10	Ø12	Ø16	Ø20	Ø25	Ø32
Rebar BSt 500 S	$N_{Rk,s}$	[kN]	28	43	62	111	173	270	442
Partial safety factor	γ_{Ms}	[-]	1,4						

Combined pullout and concrete cone failure in uncracked concrete C20/25									
Size			Ø8	Ø10	Ø12	Ø16	Ø20	Ø25	Ø32
Characteristic bond resistance in uncracked concrete for a working life of 50 years and 100 years									
Dry and wet concrete	$\tau_{Rk,ucr}$	[N/mm ²]	12	10	10	9	9	9	5,5
Installation safety factor	γ_{inst}	[-]	1,2						
Flooded hole	$\tau_{Rk,ucr}$	[N/mm ²]	12	10	10	9	9	9	5,5
Installation safety factor	γ_{inst}	[-]	1,4						
Factor for influence of sustained load for a working life 50 years	ψ^0_{sus}	[-]	0,73						
Factor for concrete C50/60	ψ_c	[-]	1						

Concrete cone failure									
Factor for concrete cone failure	$k_{ucr,N}$	[-]	11						
Edge distance	$c_{cr,N}$	[mm]	1,5 h_{ef}						

Splitting failure									
Size			Ø8	Ø10	Ø12	Ø16	Ø20	Ø25	Ø32
Edge distance	$c_{cr,sp}$	[mm]	1,5 h_{ef}						
Spacing	$s_{cr,sp}$	[mm]	3,0 h_{ef}						

PROFIX PIT+, PROFIX PIT COLD+, PROFIX PIT HOT+

Performances

Design according to EN 1992-4
Characteristic resistance for tension loads - rebar

Annex C 3

Table C4: Design method EN 1992-4
 Characteristic values of resistance to tension load of rebar for
 PROFIX PIT COLD+ with installation temperature < -10°C

Steel failure – Characteristic resistance							
See Annex C 3							

Combined pullout and concrete cone failure in uncracked concrete C20/25								
Size		Ø8	Ø10	Ø12	Ø16	Ø20	Ø25	Ø32
Characteristic bond resistance in uncracked concrete for a working life of 50 years and 100 years								
Dry and wet concrete	$\tau_{Rk,ucr}$ [N/mm ²]	11,5	9,5	9,5	9,0	8,5	8,5	5,5
Installation safety factor	γ_{inst} [-]	1,2						
Flooded hole	$\tau_{Rk,ucr}$ [N/mm ²]	11,5	9,5	9,5	9,0	8,5	8,5	5,5
Installation safety factor	γ_{inst} [-]	1,4						
Factor for influence of sustained load for a working life 50 years	ψ^{0}_{sus} [-]	0,73						
Factor for concrete C50/60	ψ_c [-]	1						

Concrete cone failure							
See Annex C 3							

Splitting failure							
See Annex C 3							

PROFIX PIT COLD+	Annex C 4
Performances Design according to EN 1992-4 Characteristic resistance for tension loads - rebar	

Table C5: Design method EN 1992-4
Characteristic values of resistance to shear load of threaded rod

Steel failure without lever arm									
Size		M8	M10	M12	M16	M20	M24	M27	M30
Steel grade 4.6	$V_{Rk,s}$ [kN]	7	12	17	31	49	71	92	112
Partial safety factor	γ_{Ms} [-]	1,67							
Steel grade 5.8	$V_{Rk,s}$ [kN]	9	15	21	39	61	88	115	140
Partial safety factor	γ_{Ms} [-]	1,25							
Steel grade 8.8	$V_{Rk,s}$ [kN]	15	23	34	63	98	141	184	224
Partial safety factor	γ_{Ms} [-]	1,25							
Steel grade 10.9	$V_{Rk,s}$ [kN]	18	29	42	79	123	177	230	281
Partial safety factor	γ_{Ms} [-]	1,5							
Stainless steel grade A2-70, A4-70	$V_{Rk,s}$ [kN]	13	20	30	55	86	124	161	196
Partial safety factor	γ_{Ms} [-]	1,56							
Stainless steel grade A4-80	$V_{Rk,s}$ [kN]	15	23	34	63	98	141	184	224
Partial safety factor	γ_{Ms} [-]	1,33							
Stainless steel grade 1.4529	$V_{Rk,s}$ [kN]	13	20	30	55	86	124	161	196
Partial safety factor	γ_{Ms} [-]	1,25							
Stainless steel grade 1.4565	$V_{Rk,s}$ [kN]	13	20	30	55	86	124	161	196
Partial safety factor	γ_{Ms} [-]	1,56							
Characteristic resistance of group of fasteners									
Ductility factor $k_7 = 1,0$ for steel with rupture elongation $A_5 > 8\%$									

Steel failure with lever arm									
Size		M8	M10	M12	M16	M20	M24	M27	M30
Steel grade 4.6	$M^o_{Rk,s}$ [N.m]	15	30	52	133	260	449	666	900
Partial safety factor	γ_{Ms} [-]	1,67							
Steel grade 5.8	$M^o_{Rk,s}$ [N.m]	19	37	66	166	325	561	832	1125
Partial safety factor	γ_{Ms} [-]	1,25							
Steel grade 8.8	$M^o_{Rk,s}$ [N.m]	30	60	105	266	519	898	1332	1799
Partial safety factor	γ_{Ms} [-]	1,25							
Steel grade 10.9	$M^o_{Rk,s}$ [N.m]	37	75	131	333	649	1123	1664	2249
Partial safety factor	γ_{Ms} [-]	1,50							
Stainless steel grade A2-70, A4-70	$M^o_{Rk,s}$ [N.m]	26	52	92	233	454	786	1165	1574
Partial safety factor	γ_{Ms} [-]	1,56							
Stainless steel grade A4-80	$M^o_{Rk,s}$ [N.m]	30	60	105	266	519	898	1332	1799
Partial safety factor	γ_{Ms} [-]	1,33							
Stainless steel grade 1.4529	$M^o_{Rk,s}$ [N.m]	26	52	92	233	454	786	1165	1574
Partial safety factor	γ_{Ms} [-]	1,25							
Stainless steel grade 1.4565	$M^o_{Rk,s}$ [N.m]	26	52	92	233	454	786	1165	1574
Partial safety factor	γ_{Ms} [-]	1,56							
Concrete pry-out failure									
Factor for resistance to pry-out failure	k_8 [-]	2							

Concrete edge failure									
Size		M8	M10	M12	M16	M20	M24	M27	M30
Outside diameter of fastener	d_{nom} [mm]	8	10	12	16	20	24	27	30
Effective length of fastener	l_f [mm]	min (h_{ef} , $8 d_{nom}$)							

PROFIX PIT+, PROFIX PIT COLD+, PROFIX PIT HOT+

Performances

Design according to EN 1992-4
Characteristic resistance for shear loads - threaded rod

Annex C 5

Table C6: Design method EN 1992-4
Characteristic values of resistance to shear load of rebar

Steel failure without lever arm								
Size		Ø8	Ø10	Ø12	Ø16	Ø20	Ø25	Ø32
Rebar BSt 500 S	$V_{Rk,s}$ [kN]	14	22	31	55	86	135	221
Partial safety factor	γ_{Ms} [-]	1,5						
Characteristic resistance of group of fasteners								
Ductility factor $k_7 = 1,0$ for steel with rupture elongation $A_5 > 8\%$								

Steel failure with lever arm								
Size		Ø8	Ø10	Ø12	Ø16	Ø20	Ø25	Ø32
Rebar BSt 500 S	$M^o_{Rk,s}$ [N.m]	33	65	112	265	518	1013	2122
Partial safety factor	γ_{Ms} [-]	1,5						
Concrete pry-out failure								
Factor for resistance to pry-out failure	k_8 [-]	2						

Concrete edge failure								
Size		Ø8	Ø10	Ø12	Ø16	Ø20	Ø25	Ø32
Outside diameter of fastener	d_{nom} [mm]	8	10	12	16	20	25	32
Effective length of fastener	l_f [mm]	min (h_{ef} , 8 d_{nom})						

PROFIX PIT+, PROFIX PIT COLD+, PROFIX PIT HOT+	Annex C 6
Performances Design according to EN 1992-4 Characteristic resistance for shear loads - rebar	

Table C7: Displacement of threaded rod under tension and shear load





Size		M8	M10	M12	M16	M20	M24	M27	M30
Tension load									
Uncracked concrete									
δ_{N0}	[mm/kN]	0,05	0,04	0,03	0,02	0,02	0,02	0,01	0,01
$\delta_{N\infty}$	[mm/kN]	0,11	0,09	0,06	0,04	0,03	0,02	0,02	0,02
Cracked concrete									
δ_{N0}	[mm/kN]		0,08	0,09	0,05	0,03	0,02		
$\delta_{N\infty}$	[mm/kN]		0,51	0,32	0,18	0,13	0,11		
Shear load									
δ_{V0}	[mm/kN]	0,48	0,30	0,20	0,11	0,10	0,08	0,06	0,05
$\delta_{V\infty}$	[mm/kN]	0,72	0,45	0,30	0,17	0,14	0,12	0,10	0,08

Table C8: Displacement of rebar under tension and shear load

Size		Ø8	Ø10	Ø12	Ø16	Ø20	Ø25	Ø32
Tension load								
Uncracked concrete								
δ_{N0}	[mm/kN]	0,04	0,03	0,02	0,02	0,01	0,01	0,01
$\delta_{N\infty}$	[mm/kN]	0,09	0,07	0,05	0,03	0,02	0,01	0,01
Shear load								
δ_{V0}	[mm/kN]	0,05	0,04	0,03	0,02	0,01	0,01	0,01
$\delta_{V\infty}$	[mm/kN]	0,08	0,06	0,05	0,03	0,02	0,01	0,01

PROFIX PIT+, PROFIX PIT COLD+, PROFIX PIT HOT+

Performances
Displacement

Annex C 7

Table C9: Seismic performance category C1

Size			M10	M12	M16	M20	M24
Tension load							
Steel failure							
Characteristic resistance grade 4.6	$N_{Rk,s,C1}$	[kN]	23	34	63	98	141
Partial safety factor	γ_{Ms}	[-]	2,00				
Characteristic resistance grade 5.8	$N_{Rk,s,C1}$	[kN]	29	42	79	123	177
Partial safety factor	γ_{Ms}	[-]	1,50				
Characteristic resistance grade 8.8	$N_{Rk,s,C1}$	[kN]	46	67	126	196	282
Partial safety factor	γ_{Ms}	[-]	1,50				
Characteristic resistance grade 10.9	$N_{Rk,s,C1}$	[kN]	58	84	157	245	353
Partial safety factor	γ_{Ms}	[-]	1,33				
Characteristic resistance A2-70, A4-70	$N_{Rk,s,C1}$	[kN]	41	59	110	172	247
Partial safety factor	γ_{Ms}	[-]	1,87				
Characteristic resistance A4-80	$N_{Rk,s,C1}$	[kN]	46	67	126	196	282
Partial safety factor	γ_{Ms}	[-]	1,60				
Characteristic resistance 1.4529	$N_{Rk,s,C1}$	[kN]	41	59	110	172	247
Partial safety factor	γ_{Ms}	[-]	1,50				
Characteristic resistance 1.4565	$N_{Rk,s,C1}$	[kN]	41	59	110	172	247
Partial safety factor	γ_{Ms}	[-]	1,87				
Characteristic resistance to pull-out for a working life of 50 years							
Dry, wet concrete and flooded hole	$\tau_{Rk,C1}$	[N/mm ²]	5,5	5,5	5,5	4,2	5,0
Characteristic resistance to pull-out for a working life of 100 years							
Dry, wet concrete and flooded hole	$\tau_{Rk,C1}$	[N/mm ²]	3,8	3,8	4,0	2,6	3,8
Installation safety factor – Dry and wet concrete	γ_{inst}	[-]	1,2				
Installation safety factor – Flooded hole	γ_{inst}	[-]	1,4				

Shear load							
Steel failure without lever arm							
Characteristic resistance grade 4.6	$V_{Rk,s,C1}$	[kN]	7	10	23	30	40
Partial safety factor	γ_{Ms}	[-]	1,67				
Characteristic resistance grade 5.8	$V_{Rk,s,C1}$	[kN]	9	13	28	38	51
Partial safety factor	γ_{Ms}	[-]	1,25				
Characteristic resistance grade 8.8	$V_{Rk,s,C1}$	[kN]	14	21	45	61	81
Partial safety factor	γ_{Ms}	[-]	1,25				
Characteristic resistance grade 10.9	$V_{Rk,s,C1}$	[kN]	18	26	56	76	101
Partial safety factor	γ_{Ms}	[-]	1,50				
Characteristic resistance A2-70, A4-70	$V_{Rk,s,C1}$	[kN]	12	18	39	53	71
Partial safety factor	γ_{Ms}	[-]	1,56				
Characteristic resistance A4-80	$V_{Rk,s,C1}$	[kN]	14	21	45	61	81
Partial safety factor	γ_{Ms}	[-]	1,33				
Characteristic resistance 1.4529	$V_{Rk,s,C1}$	[kN]	12	18	39	53	71
Partial safety factor	γ_{Ms}	[-]	1,25				
Characteristic resistance 1.4565	$V_{Rk,s,C1}$	[kN]	12	18	39	53	71
Partial safety factor	γ_{Ms}	[-]	1,56				
Characteristic shear load resistance $V_{Rk,s,eq}$ in the Table C7 shall be multiplied by following reduction factor for hot-dip galvanized commercial standard rods							
Reduction factor for hot-dip galvanized rods	$\alpha_{v,h-dg,c1}$	[-]	0,57	0,56	0,49	0,56	0,61
Factor for annular gap	α_{gap}	[-]	0,5				

The anchor shall be used with minimum rupture elongation after fracture A_5 equal to 19%.

Note: Rebars are not qualified for seismic design

PROFIX PIT+, PROFIX PIT COLD+, PROFIX PIT HOT+

Performances
Seismic performance category C1

Annex C 8

Table C10: Seismic performance category C2

Size			M12	M16	M20
Tension load					
Steel failure					
Characteristic resistance grade 4.6	$N_{Rk,s,C2}$	[kN]	34	63	98
Partial safety factor	γ_{Ms}	[-]	2,00		
Characteristic resistance grade 5.8	$N_{Rk,s,C2}$	[kN]	42	79	123
Partial safety factor	γ_{Ms}	[-]	1,50		
Characteristic resistance grade 8.8	$N_{Rk,s,C2}$	[kN]	67	126	196
Partial safety factor	γ_{Ms}	[-]	1,50		
Characteristic resistance grade 10.9	$N_{Rk,s,C2}$	[kN]	84	157	245
Partial safety factor	γ_{Ms}	[-]	1,33		
Characteristic resistance A2-70, A4-70	$N_{Rk,s,C2}$	[kN]	59	110	172
Partial safety factor	γ_{Ms}	[-]	1,87		
Characteristic resistance A4-80	$N_{Rk,s,C2}$	[kN]	67	126	196
Partial safety factor	γ_{Ms}	[-]	1,60		
Characteristic resistance 1.4529	$N_{Rk,s,C2}$	[kN]	59	110	172
Partial safety factor	γ_{Ms}	[-]	1,50		
Characteristic resistance 1.4565	$N_{Rk,s,C2}$	[kN]	59	110	172
Partial safety factor	γ_{Ms}	[-]	1,87		
Characteristic resistance to pull-out for a working life of 50 years					
Dry, wet concrete and flooded hole	$\tau_{Rk,C2}$	[N/mm ²]	1,2	1,4	1,6
Characteristic resistance to pull-out for a working life of 100 years					
Dry, wet concrete and flooded hole	$\tau_{Rk,C2}$	[N/mm ²]	0,8	1,0	1,0
Installation safety factor – Dry and wet concrete	γ_{inst}	[-]	1,2		
Installation safety factor – Flooded hole	γ_{inst}	[-]	1,4		
Shear load					
Steel failure without lever arm					
Characteristic resistance grade 4.6	$V_{Rk,s,C2}$	[kN]	13	18	28
Partial safety factor	γ_{Ms}	[-]	1,67		
Characteristic resistance grade 5.8	$V_{Rk,s,C2}$	[kN]	16	22	35
Partial safety factor	γ_{Ms}	[-]	1,25		
Characteristic resistance grade 8.8	$V_{Rk,s,C2}$	[kN]	25	36	56
Partial safety factor	γ_{Ms}	[-]	1,25		
Characteristic resistance grade 10.9	$V_{Rk,s,C2}$	[kN]	32	45	70
Partial safety factor	γ_{Ms}	[-]	1,50		
Characteristic resistance A2-70, A4-70	$V_{Rk,s,C2}$	[kN]	22	31	49
Partial safety factor	γ_{Ms}	[-]	1,56		
Characteristic resistance A4-80	$V_{Rk,s,C2}$	[kN]	25	36	56
Partial safety factor	γ_{Ms}	[-]	1,33		
Characteristic resistance 1.4529	$V_{Rk,s,C2}$	[kN]	22	31	49
Partial safety factor	γ_{Ms}	[-]	1,25		
Characteristic resistance 1.4565	$V_{Rk,s,C2}$	[kN]	22	31	49
Partial safety factor	γ_{Ms}	[-]	1,56		
Characteristic shear load resistance $V_{Rk,s,eq}$ in the Table C8 shall be multiplied by following reduction factor for hot-dip galvanized commercial standard rods					
Reduction factor for hot-dip galvanized rods	$\alpha_{v,h-dg,c2}$	[-]	0,46	0,61	0,61
Factor for annular gap	α_{gap}	[-]	0,5		

Table C11: Displacement under tensile and shear load - seismic category C2

Size		M12	M16	M20
$\delta_{N,eq}(DLS)$	[mm]	0,57	0,35	0,85
$\delta_{N,eq}(ULS)$	[mm]	7,62	6,75	7,28
$\delta_{V,eq}(DLS)$	[mm]	5,29	4,12	4,94
$\delta_{V,eq}(ULS)$	[mm]	10,20	9,05	10,99

The anchor shall be used with minimum rupture elongation after fracture A_5 equal to 19%.

Note: Rebars are not qualified for seismic design

PROFIX PIT+, PROFIX PIT COLD+, PROFIX PIT HOT+

Performances
Seismic performance category C2

Annex C 9

Table C12: Seismic performance category C1 for PROFIX PIT COLD+ with installation temperature < -10°C

Size		M10	M12	M16	M20	M24
Tension load						
Steel failure						
See Annex C 8						
Characteristic resistance to pull-out for a working life of 50 years						
Dry, wet concrete and flooded hole	$\tau_{RK,C1}$ [N/mm ²]	5,3	5,5	5,5	4,0	4,9
Characteristic resistance to pull-out for a working life of 100 years						
Dry, wet concrete and flooded hole	$\tau_{RK,C1}$ [N/mm ²]	3,7	3,7	3,9	2,4	3,7
Installation safety factor – Dry and wet concrete	γ_{inst}	[-]		1,2		
Installation safety factor – Flooded hole	γ_{inst}	[-]		1,4		

Shear load						
Steel failure without lever arm						
See Annex C 8						
Factor for annular gap	α_{gap}	[-]		0,5		

The anchor shall be used with minimum rupture elongation after fracture A_5 equal to 19%.

Note: Rebars are not qualified for seismic design

Table C13: Seismic performance category C2 for PROFIX PIT COLD+ with installation temperature < -10°C

Size		M12	M16	M20
Tension load				
Steel failure				
See Annex C 9				
Characteristic resistance to pull-out for a working life of 50 years				
Dry, wet concrete and flooded hole	$\tau_{RK,C2}$ [N/mm ²]	1,1	1,3	1,5
Characteristic resistance to pull-out for a working life of 100 years				
Dry, wet concrete and flooded hole	$\tau_{RK,C2}$ [N/mm ²]	0,7	0,9	0,9
Installation safety factor – Dry and wet concrete	γ_{inst}	[-]		1,2
Installation safety factor – Flooded hole	γ_{inst}	[-]		1,4
Shear load				
Steel failure without lever arm				
See Annex C 9				
Factor for annular gap	α_{gap}	[-]		0,5

PROFIX PIT COLD+

Performances
Seismic performance category C2

Annex C 10